



UniCal Rtd+

**Universal Resistance Thermometers
indicator-simulator**

Instruction Manual ed. 04



INTRODUCTORY NOTE

ATTENTION: THIS MANUAL MUST BE REFERRED TO INSTRUMENTS WITH SERIAL NUMBER 0010088 ONWARDS.

*This publication contains operating instructions, as well as a description of the principles of operation, of **UniCal Rtd** palmtop calibrator.*

This information covers all models of the instrument, including the basic equipment and its options and accessories. This manual is a complete "USER GUIDE", providing step-by-step instructions to operate the instrument in each of its designed functions.

***Eurotron** has used the best care and efforts in preparing this book and believes the information in this publication are accurate. The **Eurotron** products are subjected to continuous improvement, in order to pursue the technological leadership; these improvements could require changes to the information of this book.*

***Eurotron** reserves the right to change such information without notice.*

*No part of this document may be stored in a retrieval system, or transmitted in any form, electronic or mechanical, without prior written permission of **Eurotron**.*

***UniCal Rtd** uses sophisticated analogic and digital technologies. Any maintenance operation must be carried out by qualified personnel **ONLY**. We recommend to contact our technicians for any support requirements.*

***UniCal Rtd** is fully tested in conformity with the directive n°89/336/CEE Electromagnetic Compatibility. **Eurotron** shall not be liable in any event, technical and publishing error or omissions, for any incidental and consequential damages, in connection with, or arising out of the use of this book.*



All right reserved
Copyright © 1996, 2004

EUROPEAN Headquarters
Eurotron Instruments SpA
Viale F.lli Casiraghi 409/413
20099 Sesto S. Giovanni (MI)
Tel. : +39-02 24 88 201
FAX: +39-02 24 40 286
Mail: info@eurotron.com

USA Headquarters
E-Instruments Group LLC
172 Middletown Blvd – Suite B201
Langhorne, PA 19047
Tel.: 215 750 1212
FAX: 215 750 1399
Mail: info@einstrumentsgroup.com



SUMMARY

1	GENERAL PERFORMANCE	5
1.1	Instrument codes	6
1.2	Specifications	7
1.2.1	Table of ranges and accuracies	8
2	GENERAL FEATURES	9
2.1	Input and output flexibility	9
2.2	Self calibration	9
2.3	Keyboard	9
2.4	Display	9
2.5	Digital interface	9
2.6	Scale factor function	9
2.7	Average measurements	9
2.8	Hold measurement	10
2.9	Simulation mode	10
2.10	Store and Autoscan	10
2.11	Case	10
3	PHYSICAL DESCRIPTION	11
4	FUNCTIONAL DESCRIPTION	12
4.1	Power supply	12
4.2	Operative keyboard	12
4.3	Input circuit	13
4.4	Microcontroller	13
4.5	Firmware	13
4.6	Digital display	14
4.7	Resistance and Rtd measurements	14
4.8	Resistance and Rtd simulation	14
4.9	Battery charger. Operation from line source (For Ni-Cd batteries only)	15
4.10	Digital interface	15
5	UNPACKING	16
6	PRE-OPERATIONAL CHECK	17
7	ELECTRICAL CONNECTIONS	18
8	OPERATIONS & APPLICATIONS	19
8.1	Rechargeable batteries (option)	19
8.2	Battery charger (for Ni-Cd batteries). Power supplied from power line ac	19
8.3	Power "ON"	19
8.4	Battery voltage indication	20
8.5	Operating mode set-up	21
8.5.1	IN / OUT function selection	21
8.5.2	Parameter or sensor selection	21
8.5.3	°C / °F Selection	22
8.5.4	Decimal point position	22
8.5.5	Average readings	22
8.5.6	Hold feature	22
8.5.7	IN / OUT data memory	23
8.5.7.1	Data memory manual scanning	23
8.5.8	Simulation Programs	25
8.5.9	ITS90 - IPTS68 Temperature Scale selection	27
8.5.10	Scale Factor Mode	27
8.5.11	Installation parameter mode	28
8.5.11.1	Firmware release code	28
8.6	Faulty operating conditions	28
8.7	Digital interface	30
8.7.2	Digital output wiring practice	30
8.7.3	TTL to RS232 Adaptor	31
8.7.4	Communication Protocol from UniCal Rtd to a PC	31
8.7.5	Computer request for UniCal settings	33



8.7.6	Communication Programs	35
9	MAINTENANCE	38
9.1	Safety recommendations	38
9.2	Spare parts	38
9.3	Storage	38
10	CERTIFICATES	39
10.1	Certificate of warranty	39
10.2	Certificate of conformity	39



1 GENERAL PERFORMANCE

A complete system for testing, measuring and calibrating built in a single, compact portable instrument.

The portable calibrator **UniCal Rtd +** is a multifunction instrument designed to meet, in a modern and practical way, the needs of instrumentation engineers, both in laboratory and field work.

Accurate, compact, rugged, easy to use; the ideal solution for measurement and simulation of:

- **ohm**
- **temperature with resistance thermometers**

The **UniCal Rtd +** has been developed using the most advanced microprocessor technology to provide high accuracy on extended ranges and a powerful operative flexibility.

Linearization algorithms of the characteristic curves of thermocouples are held in the microprocessor memory in accordance with IEC / ANSI and DIN standards. Platinum thermometers Pt100, Pt200, Pt500, Pt1000; Nickel thermometers Ni100, Ni120; Copper thermometers Cu10, Cu100 fitted with both IPTS68 and new international scale ITS90.

The selection of the operative mode is made on the polycarbonate membrane keyboard with a working life up to one million operations per key.

Both measured and simulated values are indicated on a high quality LCD dot matrix display which assures good contrast even in poor light conditions.

A menu-driven procedure allows the generation of sixty memory stored values, or a continuous or step ramp output.

The instrument carries out mathematical functions for measuring the average values of unstable signals.

The case, made of shock-resistant ABS, is ergonomically designed for easy practical use.

As option the instrument can be powered by four Ni-Cd rechargeable batteries (1.2 V nominal); an external battery charger is supplied as a standard accessory.



1.1 Instrument codes

cat. 3112 - A - B

UniCal Rtd + (cat. 3112) **Basic instrument**
Supplied with a vinyl case and an instruction manual.

<u>Table</u>	<u>A</u>	<u>Power Supply</u>
	0	Alkaline batteries
	1	Ni-MH / 120 V with USA plug
	2	Ni-MH / 230 V with SCHUKO plug
	3	Ni-MH / 240 V with UK plug
	4	Ni-MH / 230 V with European plug
	5	Ni-MH / 100 V with USA/Japan plug

<u>Table</u>	<u>B</u>	<u>Report of Calibration</u>
	1	EUROTRON Report
	9	Special Report

Accessories

BB530003	TTL to RS232 normal adaptor
BB530004	TTL to RS232 isolated converter



1.2 Specifications

- **In/Out parameters:**
see table
- **In/Out ranges:**
see table
- **Resolution:**
see table
- **Limits of error:**
see table
- **Common mode rejection:**
> 130 dB at 50/60 Hz
- **Normal mode rejection:**
> 60 dB at 50/60 Hz
- **Temperature stability:**
span: $\pm 0.01\%$ of the reading/ $^{\circ}\text{C}$
zero : $\pm 0.2 \mu\Omega/^{\circ}\text{C}$
- **Simulation excitation current:**
0.3 to 3mA (up to 400Ω)
0.03 to 0,3mA (up to 4000Ω)
- **Measurement excitation current:**
0.5mA (up to 400Ω)
0.05mA (up to 4000Ω)
- **Rtd cable compensation:**
 100Ω max
- **Display:**
high contrast dot matrix LCD
(7x5 dots per character - 16 characters)
- **Scale Factor:**
 R_0 and α adjustable for linear interpolation
- **Calibration:**
automatic procedure
- **Power supply:**
n.4 Alkaline or rechargeable Ni-Cd batteries 1.25V 0.7 Ah
- **Battery life:**
8 hours (Ni-Cd Batteries) - 20 hours (Alkaline Batteries)
- **Recharge time:**
8 hours with instrument switched -OFF-
- **Battery voltage:**
display indicated value
- **Program release identification:**
version number indicated on the display
- **Operating temperature range:**
from -5°C to $+50^{\circ}\text{C}$ (23 to 122°F)
- **Storage temperature range:**
from -30°C to $+60^{\circ}\text{C}$ (-22 to 140°F)
- **Case:**
ABS
- **Dimensions:**
 $215 \times 96 \times 35$ mm
- **Weights:**
net 1 Kg (2.2 lbs)
gross with packing 2.5 Kg



1.2.1 Table of ranges and accuracies

IN-OUT RANGES

Sensor or parameter	Total range	Resolution	Accuracy (% of reading)	Reference
Pt100 $\alpha=3850$	-200 to 850°C -328 to 1562°F	0.1°C 0.1°F	$\pm(0.04\% + 0.1^\circ\text{C})$ $\pm(0.04\% + 0.18^\circ\text{F})$	IEC751 - DIN 43760
Pt100 $\alpha=3902$	-200 to 650°C -328 to 1202°F	0.1°C 0.1°F	$\pm(0.04\% + 0.1^\circ\text{C})$ $\pm(0.04\% + 0.18^\circ\text{F})$	US
Pt100 $\alpha=3926$	-200 to 850°C -328 to 1562°F	0.1°C 0.1°F	$\pm(0.04\% + 0.1^\circ\text{C})$ $\pm(0.04\% + 0.18^\circ\text{F})$	US Lab
Pt100 $\alpha=3923$	-200 to 600°C -328 to 1112°F	0.1°C 0.1°F	$\pm(0.04\% + 0.2^\circ\text{C})$ $\pm(0.04\% + 0.36^\circ\text{F})$	SAMA
Pt100 $\alpha=3910$	-200 to 850°C -328 to 1562°F	0.1°C 0.1°F	$\pm(0.04\% + 0.2^\circ\text{C})$ $\pm(0.04\% + 0.36^\circ\text{F})$	OIML 1985
Pt100 $\alpha=3916$	-200 to 600°C -328 to 1112°F	0.1°C 0.1°F	$\pm(0.04\% + 0.3^\circ\text{C})$ $\pm(0.04\% + 0.54^\circ\text{F})$	JIS JEMINA 1981
Ni100 $\alpha=617$	-60 to 180°C -76 to 356°F	0.1°C 0.1°F	$\pm(0.04\% + 0.2^\circ\text{C})$ $\pm(0.04\% + 0.36^\circ\text{F})$	
Ni120 $\alpha=672$	0 to 150°C 32 to 302°F	0.1°C 0.1°F	$\pm(0.04\% + 0.3^\circ\text{C})$ $\pm(0.04\% + 0.54^\circ\text{F})$	
Cu10 $\alpha=42$	-70 to 150°C -94 to 302°F	1°C 1°F	$\pm(0.04\% + 0.3^\circ\text{C})$ $\pm(0.04\% + 0.54^\circ\text{F})$	
Cu100 $\alpha=42$	-180 to 150°C -292 to 302°F	0.1°C 0.1°F	$\pm(0.04\% + 0.1^\circ\text{C})$ $\pm(0.04\% + 0.18^\circ\text{F})$	
Pt200 $\alpha=3850$	-200 to 760°C -328 to 1562°F	1°C 1°F	$\pm(0.04\% + 0.1^\circ\text{C})$ $\pm(0.04\% + 0.18^\circ\text{F})$	
Pt500 $\alpha=3850$	-200 to 850°C -328 to 1562°F	0.1°C 0.1°F	$\pm(0.04\% + 0.1^\circ\text{C})$ $\pm(0.04\% + 0.18^\circ\text{F})$	
Pt1000 $\alpha=3850$	-200 to 850°C -328 to 1562°F	0.1°C 0.1°F	$\pm(0.04\% + 0.1^\circ\text{C})$ $\pm(0.04\% + 0.18^\circ\text{F})$	
Pt1000 $\alpha=3910$	-200 to 850°C -328 to 1562°F	0.1°C 0.1°F	$\pm(0.04\% + 0.1^\circ\text{C})$ $\pm(0.04\% + 0.18^\circ\text{F})$	OIML 1985
Ω IN	0 to 300 Ω 20 to 3000 Ω 0 to 400 Ω 20 to 4000 Ω	10m Ω 0.1 Ω 0.1 Ω 1 Ω	$\pm(0.04\% + 27\text{m}\Omega)$ $\pm(0.04\% + 270\text{m}\Omega)$ $\pm(0.04\% + 27\text{m}\Omega)$ $\pm(0.04\% + 270\text{m}\Omega)$	
Ω OUT	0 to 300 Ω 20 to 3000 Ω 0 to 400 Ω 20 to 4000 Ω	10m Ω 0.1 Ω 0.1 Ω 1 Ω	$\pm(0.04\% + 35\text{m}\Omega)$ $\pm(0.04\% + 350\text{m}\Omega)$ $\pm(0.04\% + 35\text{m}\Omega)$ $\pm(0.04\% + 350\text{m}\Omega)$	

Note:

- The relative accuracies shown above are stated for 90 days and the operative conditions are +23°C \pm 2°C
- The typical 1 year's relative accuracy can be estimated by multiplying the "% of reading" specifications by 1.6.
- All input ranges: additional error \pm 1 digit.
- The traceability chart and uncertainty data can be supplied on request.



2 GENERAL FEATURES

2.1 Input and output flexibility

Ease of operation has been achieved using advanced microprocessor technology. Each instrument, through a menu-driven procedure, allows measurement or simulation of ohms, or temperature with all normalized IEC / ANSI and DIN, resistance thermometers Pt100, Pt200, Pt500, Pt1000, Ni100, Ni120, Cu10, Cu100.

The microprocessor performs automatic polynomial linearization.

°C or °F and ITS90 or ITS568 selection is made directly on the membrane keyboard.

2.2 Self calibration

The hardware-firmware design allows for an automatic calibration of the instrument.

An high precision resistor (400Ω, 4000Ω) and a ohmmeter are necessary.

The calibration procedure is protected by a security code .

2.3 Keyboard

A tactile polycarbonate membrane keyboard, with a working life of one million operations per key, protects the internal electronics from the surrounding environment.

It allows the selection of the operative mode, the type of resistance thermometers and the setting of simulation values with fast and slow upgrading.

A "bip" sound indicates that the instrument has received and acknowledged the keyboard operator instruction.

Contact closure of membrane keys is acknowledged, as a coded signal, directly by the microprocessor.

2.4 Display

The high quality alphanumeric dot matrix LCD display (7x5 dots per character - 16 characters) allows easy readings even in poor light conditions.

The operative mode (measurement or simulation), the technical unit and the signal value are simultaneously indicated.

2.5 Digital interface

A digital interface, with TTL logic levels, is available as a standard for communications with external units.

A 4 wire cable, with a male mini connector, and an auxiliary module for TTL to RS232 conversion is available as an option.

2.6 Scale factor function

Easy, menu-driven set-up, to read or simulate custom resistance thermometer adjusting R_0 and α (linear interpolation). The display will indicate the scaled input / output value in °C or °F. It is possible to include IPTS90 current correction.

2.7 Average measurements



The measurement of unstable input signals is accomplished with a progressive averaging each 32 conversions (approximately 10 seconds).

2.8 Hold measurement

To hold the actual measurement on the display.

2.9 Simulation mode

Menu-driven set-up to generate a continuous step ramp output.

The total time, the start point, the end point and step size are requested by the set-up procedure to run the program.

A manual repeat increment is also possible (Autostep).

2.10 Store and Autoscan

Up to 60 values can be stored in the internal memory to create an automatic calibration procedure.

Autoscan function avoids the need to recall in sequence all stored values.

Input value can also be stored.

2.11 Case

The case is designed for easy hand held operation and transport.

The body is injection moulded, shock-resistant ABS.

A soft vinyl carrying case, with shoulder strap, is supplied with the instrument as a standard accessory.



3 PHYSICAL DESCRIPTION

The **UniCal Rtd +** portable calibrator consists of a rugged and compact ABS case, a mother board with all base functions, a tactile polycarbonate membrane keyboard, an LCD display and a group of four Alkaline or Ni-Cd rechargeable batteries.

An external battery charger module is supplied as a standard accessory when the Ni-Cd battery option is installed.

The battery container is located on the back of the case and is accessible by sliding and removing the plastic cover.

The vinyl case, with shoulder strap, assures better protection of the instrument against knocks and scratches.



4 FUNCTIONAL DESCRIPTION

The UniCal Rtd + portable calibrator block diagram is shown on the figure below:

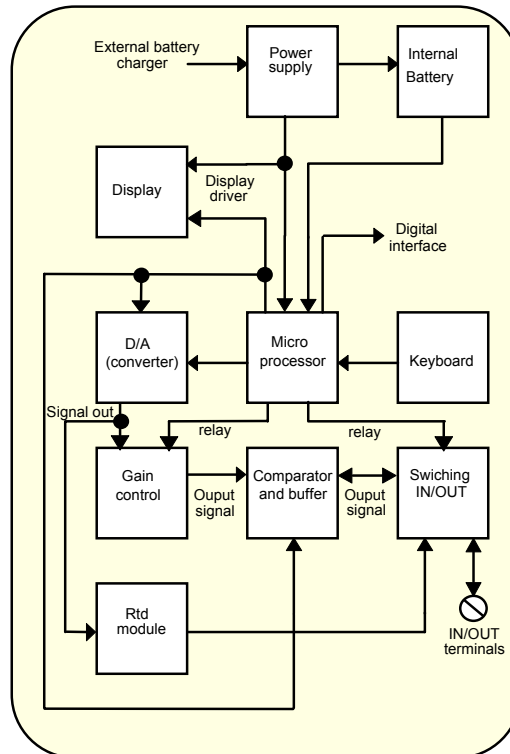

The functional blocks of the instrument are as follows:

- **power supply**
- **microcontroller (central unit + memory)**
- **input circuit**
- **LCD display**
- **membrane keyboard**
- **digital to analog converter**

4.1 Power supply

The instrument is powered by four internal batteries (AA type). The voltage battery (approximately 5 V) is connected through the <ON / OFF> key to the power supply circuit that generates a -5V for analog circuits.

4.2 Operative keyboard

The front panel is a tactile polycarbonate membrane keyboard, and has a working life of one million operations per key.

The contact closure of the membrane keyboard is acknowledged as a coded signal by the microprocessor that recognizes the operators instructions.

Keys are interconnected on a 4 x3 matrix; the microprocessor identifies directly the active key.



ON /OFF	Power ON / OFF switch
STO	Memory load keys
0.1 / 1	Decimal point selection
START	Low limit setting on ramp simulation
END	High limit setting on ramp simulation
STEP	Step value setting on ramp simulation
TIME	Total time setting on ramp simulation program.
0, 1, 2	IN / OUT memories
°C/°F	Technical unit selection
SELECT	Set-up procedure
AVERAGE	Average measurements
IN/OUT	IN / OUT mode selection
AUTORAMP	Program start
HOLD	Hold measurement
BATTERY	Battery voltage indication
ENTER	Memory load key
SHIFT	Key secondary function
LCD ±	Display contrast adjustment
▲	Simulation values cursors
▼	Simulation values cursors
FAST	Cursor accelerator

A "bip" sound indicates that the instrument has received and acknowledged the keyboard operator instruction. The explanation of the key functions is summarised at par. 8 ("OPERATIONS & APPLICATIONS").

4.3 Input circuit

The input circuit is based on the output buffer wired as an error amplifier. The input signal drives the negative channel (-) of the integrated circuit. The input signal drives the negative channel (-) of the integrated circuit. The microprocessor recognizes if the D/A converter is generating a voltage signal higher or lower than the input signal and gives correcting instructions to keep the input amplifier output on the nearest value to zero. In the above conditions the microprocessor will acknowledge the value of the input signal as equivalent to the setting of the digital to analog converter.

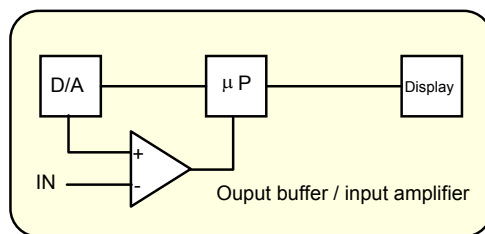

4.4 Microcontroller

The microprocessor handles all the logic functions of the instrument, performs the linearization for non linear transducers, compensates for the reference junction temperature, drives the digital display, acknowledges all operator instructions.

The heart of the circuit is a single-chip microcomputer that utilizes HCMOS technology to provide the low power characteristics and high noise immunity of CMOS plus the high speed operation of HMOS.

On-chip memory systems include a 8 Kbyte ROM and 512 bytes of electrically erasable programmable ROM (EEPROM).

The microprocessor works with an 8-bit communication bus to the EPROM and EEPROM memories.

The single-chip microcomputer incorporates a 256 bytes of static RAM and 8 channel analog to digital converter used to read the Rj value, the setting of the input comparator and the battery voltage.

4.5 Firmware



The operating system firmware handles all logic instructions to the internal peripheral circuits and performs the computation of the linearization equations.
The application system firmware is resident on the non-volatile memory (EEPROM) of the microprocessor.
It is used to store the installation parameters (autocalibration data, programs data, etc.).

4.6 Digital display

The digital display, mounted on an auxiliary board, uses high contrast LCD technology.
The character generation is by a dedicated secondary microprocessor driven by the bus of the main microprocessor.
The 16 characters are displayed in a 7 x 5 dot matrix.

4.7 Resistance and Rtd measurements

The resistance thermometer (Rtd) is connected to terminals A - B - C in a 3 - wire configuration (see figure on the next page).

Two constant current generators are provided by the auxiliary module for supplying the Rtd.

The first half of "IC1" generates the negative current

$I_A = -0.25 \text{ mA}$ that flows from terminal B to terminal A through the Rtd and line resistances RLA and RLB.

I_A is kept constant by the microprocessor that controls the zero voltage level.

The second half of "IC 1", with the associated resistors, generates the positive current I_C that flows from terminal C to terminal B through line resistances RLC and RLB.

Current I_C is kept exactly $= 2 \times I_A$, so the resultant current $I_B = I_C - I_A$ flows through RLB.

The input measured signal across terminals A and B is the algebraic sum of drop voltages across Rtd and line resistances RLA and RLB. As drop voltages across RLA and RLB are exactly the same (providing that line resistances RLA and RLB are equals), but with opposite poles, the resultant voltage across terminals A and B is proportional to Rtd resistance variation, with no influence of line resistance.

The input measured signal across terminals A and B is the algebraic sum of drop voltages across Rtd and line resistance RLA and RLB.

As drop voltages across RLA and RLB are exactly the same (providing that line resistances RLA and RLB are equals), but with opposite poles, the resultant voltage across terminals A and B is proportional to Rtd resistance variation, with no influence on line resistance.

The measured signal is then handled by the microprocessor that linearizes it and displays the corresponding value in engineering units.

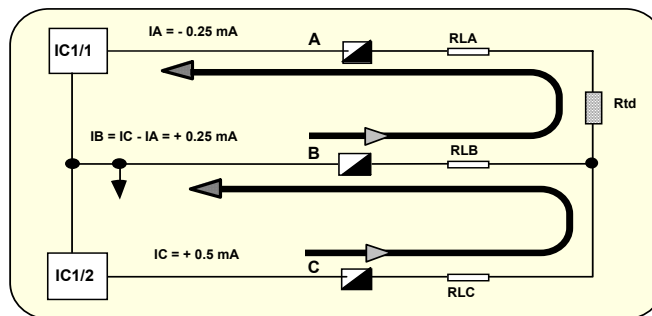

4.8 Resistance and Rtd simulation

The UniCal Rtd + calibrator is equipped with an electronic circuit for the active simulation of platinum resistance thermometers, nickel resistance thermometers and resistances.

It is based on the assumption that the instrument to be calibrated will supply the excitation current to the sensor; this current must be between 0.2 and 3 mA (typical working values).

A lower value will generate an insufficient precision level and a higher current won't permit the simulation of high resistance values (maximum voltage drop on the simulated resistance is 2 V).

The excitation current must be applied to the pertinent terminals as indicated in par. 7.1 (simulation).

That current, flowing through resistance "Ra" (precision $\pm 0.01 \%$) will generate a voltage drop that will be amplified and sent to the D/A converter.



The output amplifier will simulate the variation of the output resistance as a function of the value set by the operator through the keyboard.
The connection between “+” and “-” terminals must be left open.

4.9 Battery charger. Operation from line source (For Ni-Cd batteries only)

The auxiliary module, supplied as a standard accessory, allows operation from ac line 100 -120 - 230 or 240 Vac 50/60 Hz.

The calibrator, if needed, can be operated directly from a line source through the charger.

The charger is provided with a main plug (Schuko, USA, European, UK) and a cable for connection to the instrument.

The charger circuit is designed with an isolated transformer and a voltage stabilizer circuit.

The step-down transformer reduces the power line to a value of 10 Vac.

The above voltage is full wave rectified , filtered and stabilized.

The output voltage of 6.45 Vdc is the correct value to recharge the internal Ni-Cd batteries.

4.10 Digital interface

The serial digital interface circuit is essentially based on the serial communication interface subsystem (SCI) on the chip of the microprocessor at 0 to +5V level.

An adaptor to convert TTL to RS232 voltage levels can be obtained on request.



5 UNPACKING

Remove the instrument from its packing case and remove any shipping ties, clamps, or packing materials.

Carefully follow any instructions given on any attached tags.

Inspect the instrument for scratches, dents, damage to case corner etc. which may have occurred during shipment.

If any mechanical damage is noted, report the damage to the shipping carrier and then notify **EUROTRON** directly or its nearest agent, and retain the damaged packaging for inspection.

A label, inside the battery container, indicates the serial number of the instrument.

Refer to this number for any enquiry for service, spare parts supply or application and technical support requirements.

EUROTRON will keep a data base with all information regarding your instrument.



6 PRE-OPERATIONAL CHECK

The **UniCal Rtd +** indicator-simulator is powered by four Alkaline batteries (Ni-Cd rechargeable batteries as option).

For Ni-Cd batteries, the external battery charger may be ordered for either 110 -120 V or 220 -240 Vac power source.

To modify the charger's power voltage follow the instructions in par. 8.2.

Before using the instrument carefully verify the nominal voltage value of the charger; in case of modification do not forget to correct the pertinent label.

The instrument should be used in environments where the temperature does not exceed the specified limits (from -5°C to +50°C) and where the relative humidity is lower than 95%.

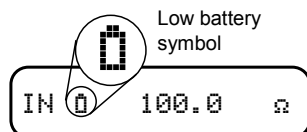

In case of "low" battery condition (voltage lower than 4.5 V \pm 0.1 V) the display will show the appropriate symbol.

A dotted symbol means that the battery package has enough power energy for about 30 minutes operation.

A black symbol means that the battery charge is below the minimum acceptable voltage level: operation of the instrument is no longer possible.

In this condition the batteries must be recharged for approximately 12 hours.

WARNING.

IF THE INSTRUMENT IS SUPPLIED WITH NI-Cd RECHARGEABLE BATTERIES. DO NOT USE NORMAL ALKALINE BATTERIES. ALKALINE BATTERIES, WHEN CONNECTED TO A DC VOLTAGE SUPPLY, UNDERTAKE AN OVERHEATING PROCESS WITH A RISK OF EXPLOSION.



7 ELECTRICAL CONNECTIONS

Although the **UniCal Rtd +** portable calibrator is designed to be insensitive to transient or noise the following recommendations should be followed to reduce ac pick up in the signal leads and to ensure good performance.

The input leads should not be run near ac line wiring, transformers and heating elements.

The figure below shows the typical input/output wiring and connections:

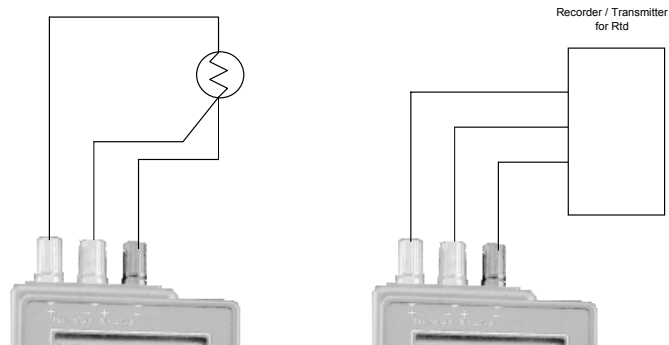



8 OPERATIONS & APPLICATIONS

The **UniCal Rtd +** portable calibrator has been factory calibrated before shipment. During start-up the operator should only select and load the pertinent application parameter as indicated in the following paragraphs.

If the instrument has been manufactured with special thermocouple table, and/or with special hardware solution, the relative documentation can be found in the plastic envelope at the end of the manual.

8.1 Rechargeable batteries (option)

On request the **UniCal Rtd +** portable calibrator can be powered by four built-in rechargeable batteries.

The instrument is shipped with an average level of charge.

After unpacking, a full charge of the battery is recommended; connect the instrument to the charger module ("OFF" condition) for a minimum period of 12 hours.

The Ni-Cd rechargeable batteries do not suffer when used in cyclic operations.

Cyclic operation is understood as a method of operation by which the battery is continually charged and discharged.

Note that a battery, at its lower limit of charge, risks a non uniform cell polarization. This condition makes it difficult to recharge with the charger supplied.

Avoid leaving the instrument, with batteries totally or partially discharged, for a long time without recharging.

To charge the batteries use only the standard module. The module incorporates protection and current limiting devices not normally found in other commercial chargers.

- When the **UniCal Rtd +** is connected to the battery charger module, by pressing **<SHIFT> + <BATTERY>** keys the indication below will be displayed:



Battery: Line Of

If a numeric value appears, it indicates that the charger is possibly faulty.

Replace the battery charger module. If the fault indication persists, replace the battery charger or contact EUROTRON Service Department.

8.2 Battery charger (for Ni-Cd batteries). Power supplied from power line ac

The external battery charger is configured, before shipment, for a supply voltage of 100 -120 - 230 or 240 Vac, upon order specification.

The nominal voltage value is indicated on the front label of the charger; if power supply voltage has to be modified, correct the indication on the front label.

To modify the power supply voltage place the jumper, mounted on the circuit board of the charger, as indicated below:

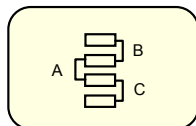

Jumper	"A":	power line at 230 V 50/60 Hz
Jumpers	"B" e "C":	power line at 120 V 50/60 Hz

8.3 Power "ON"



ATTENTION : ALL VALUES IN THE FOLLOWING FIGURES ARE ONLY LISTED AS AN EXAMPLE.

During set-up and load memory remember that the instructions of the manual related to key operation have the following meaning:

- <A> + Press the <A> key and keeping the pressure on the key, press then the key.
- <A>, Press in sequence first the <A> key and then the key.

- To power the instrument press the <ON> key. The following indication will appear for a few seconds:



- With power -ON- the instrument will run a diagnostic routine for the self-checking of critical circuits and components.
- A positive check will be shown with the indication below for about one second:



- The number indicates the version of the memory installed on the instrument.
- The instrument will be operative with the previously selected mode, e.g. as follows:

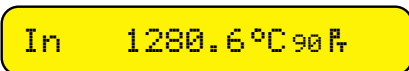

- If the number "90" is shown on the right side of the display indicates that the instrument is configured for ITS90 (International Temperature Scale 1990).
None number indicates that the instrument is configured for IPTS68 (International Practical Temperature Scale 1968). Faulty conditions will be indicated as described in par. 8.6.

8.4 Battery voltage indication

- To recall the battery voltage on the display press <SHIFT> + <BATTERY> keys.
The indication will be as follows:



- The "low" limit of the battery voltage, for the correct operation of the instrument, is +4.6 V.
- Press any key to reset the operative mode.
- During normal operating modes, (measure or simulation), the "low battery" condition will be shown with the following indication:

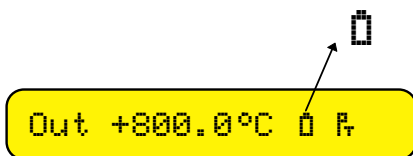

An empty symbol means that the battery has enough energy for about 30 minutes operation.
A black symbol means that the battery charge is below the minimum, batteries must be recharged.



8.5 Operating mode set-up

To select the required operating mode follow the procedures indicated below.

8.5.1 IN / OUT function selection

- Switch the instrument -ON-.
After diagnostic routine, the calibrator will be forced into the "IN" function with the active parameter previously selected (e.g. with the indication below related to a measured value of 800.0°C with resistance thermometer type Pt100):

In +800.0°C R

- Open input terminals will cause a fluctuation of the reading up to the limit of "Underflow" or "Overflow".
- To select the simulation mode press the <IN/OUT> key (indication below - simulated value of 0.0 for resistance thermometer type Pt100):

Out 0.0°C R

- The output value can be adjusted by pressing <▲> or <▼> key.
- Keep the key pressed to cause a continuous variation of the simulated value; the speed of variation will change by pressing keys <FAST> + <▲> or <FAST> + <▼> (one third significative digit per step)
- Press simultaneously the <▲> and <▼> keys to set to zero the simulated value.

8.5.2 Parameter or sensor selection

- To select the electrical parameter or the sensor required by the application follow the procedure indicated below.
- Switch the instrument -ON-.
- Press the <SELECT> key to obtain one of the menu pages indicated below:

R100 α385 IEC	R100 α3902 US
R100 α3926 UsLab	R100 α3923 SAMA
R100 α391 OIML	R100 α3916 JIS81
Ni100 α617	Ni120 α672
Cu10 α42	Cu100 α42
R200 α385 IEC	R500 α385 IEC
R1000 α385 IEC	R1000 α385 OIML
0-300.00 Ohm	0-400.0 Ohm

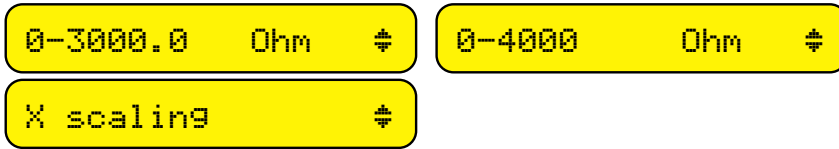

- Press <▲> or <▼> key to select the appropriate sensor.



(i.e. to activate the Pt100 with $\alpha = 0.00385$ according to IEC standard choose the sensor as indicated above)

- Press the <ENTER> key to load the selection in the memory; the instrument will return to the previous function with the new selected thermocouple, as follows:

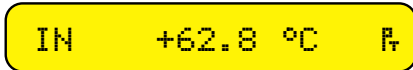

- By pressing any other key instead of <ENTER>, the instrument will not acknowledge any change and will return to the previous parameter or sensor.

8.5.3 °C / °F Selection

- To change the technical unit from °C to °F (or viceversa) press <SHIFT> + <°C/°F> keys (see the following indication):



8.5.4 Decimal point position

- The decimal point position, to increase or reduce the resolution is adjustable with keys <0.1> and <1>.

8.5.5 Average readings

The use of the "Average" mode is advised with unstable input signals.

The average represents a progressive integration of the input signal on the last 32 conversions (approximately 10 seconds).

- To enable the "Average" mode press <SHIFT> + <AVERAGE> keys.
The display will indicate as follows:



- To disable the "Average" mode press again <SHIFT> + <AVERAGE> keys.

8.5.6 Hold feature



To hold an input measurement:

- Press **<SHIFT>** + **<HOLD>** keys. The display will indicate:

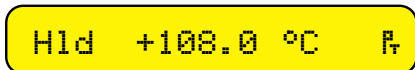

- To disable the "hold" mode, press any other key different from **<ENTER>** key.

8.5.7 IN / OUT data memory

The availability of a 60-step memory represents an important feature whether in simulation or in measurement modes.

In the measurement mode it can be useful to store input values pertinent to special test conditions.

In the simulation mode the permanent availability of calibration values can be useful, e.g. during the calibration of the scale of a recorder, indicator, transmitter.

The 60 memories are divided in 20 groups of three. The 20 groups of memory (n. 3 each group) are identified with one of the following letters:

A-B-C-D-E-F-G-H-I-J-K-L-M-N-O-P-Q-R-S-T

To select a different active group, follow this procedure:

- Press the **<SELECT>** key to obtain the following indication:



- Press **<0>** key to obtain the following indication:



- Press **<▲>** or **<▼>** key, to select the required group (from A to T).
- Press **<ENTER>** to confirm selection and selected group will become active.
- Either in measuring or simulation mode, to store memory press keys:

<SHIFT> + **<0>**

<SHIFT> + **<1>**

<SHIFT> + **<2>**

The following data are memory stored:

- operative mode
- simulation value and parameter
- decimal point position
- technical unit (°C or °F)
- internal or external Rj mode
- International temperature Scale (IPTS68 or ITS90)

- The memory stored values, relevant to the active group, can be manually recalled pressing the pertinent **<0>** or **<1>** or **<2>** key. The stored values and group selected will be kept in the memory also when the instrument is switched - OFF-.

8.5.7.1 Data memory manual scanning

The 60 stored records can be manually scanned, through the keyboard, from the first (group A - memory n. 0) to a programmable last step (group "n" - memory n. "n").

The numeric value and the parameter indicated below are an operative example e.g. to memory load 6 calibration points of the scale of a potentiometric recorder (temperature with a resistance thermometer Pt100).



1 = -50°C
2 = 0°C
3 = +100°C
4 = +200°C
5 = +300°C
6 = +400°C

As described in the previous paragraph memory store the calibration data as follows:

point 1 = group A - memory 0
point 2 = group A - memory 1
point 3 = group A - memory 2
point 4 = group B - memory 0
point 5 = group B - memory 1
point 6 = group B - memory 2

To enter the simulation program set-up follow the below indicated procedure.

- Press the <ENTER> + <RAMP/TIME> keys to obtain one of the following indication:

Time 0h 0m 1s

Time: Autostep

Time: Autoscan

- Press the <▼> key to select the last above (Time:Autoscan)
- Press the <ENTER> + <RAMP/TIME> keys to memory store the selection.
- Press one of the two <0.1°> or <1°> to return to the main operative page e.g. as it follows:

Out 0.0 °C R

- Press the <SELECT> key to enter the procedure of the selection of the last group required with the following indication:

R100 α385 IEC ±

- Press the <0> key to obtain the following indicatio:

Sel STO Group : B

- Press the <▲> or <▼> keys to select the required last group enabled.
- Press the <ENTER> key to memory store the above data. The display will return to the main indication e.g. as it follows:

Out 0.0 °C R

- Press the <RAMP> key in sequence to obtain the following data:



O 1 -50 °C R

O 2 0 °C R

O 3 +100 °C R

O 4 +200 °C R

O 5 +300 °C R

O 6 +400 °C R

- The "O" on the left side of the display indicates that the instrument is running a simulation (O=Out)
The progressive number from 1 to 6 are the memory step enabled
- To exit the procedure press one of the <0.1°> or <1°> key.
The memory stored data will be kept also when the instrument is switched -Off- and therefore ready for next requirement unless they are modified.

8.5.8 Simulation Programs

The instrument, through an easy to follow menu-driven set-up, can be programmed for simulating a continuous or step ramp output .

By programming the incremental steps to its minimum value (0.1 or 1 °C resolution) the step ramp can be assimilated to a continuous ramp.

Select first the technical unit (°C and °F), the type of thermocouple and then follow the procedure indicated below .

The procedure will consider simulation set-up in "°C" for resistance thermometer Pt100.

- To enter the set-up procedure press <SHIFT> + <TIME> keys;
the display will indicate one of the following pages:

Time: Autostep

Time: Autoscan

Time 0h 0m 1s

- Press the <▲> or <▼> keys to obtain the indication last above:
- Press the keys <▲> and <▼> to adjust the total time of the program from 0 to 20000 seconds.
- Press <ENTER> + <TIME > keys to "load memory" the value.
- Press <START> key to obtain the following indication:



Start +0.0 F

- Press <▲> and <▼> keys to set a new value.
- Press <ENTER> + <START> keys to "load memory" the new value.
- Use the same procedure to set the "end limit" and the "step value" through keys <END> and <STEP>
- Press <END> key to obtain the following indication:

End +500.0 °C F

- Press the <▲> and <▼> keys to set a new value.
- Press <ENTER> + <END> keys to load memory the new value
- Press <STEP> key to obtain the indication below:

Step +10.0 °C F

- Press <▲> and <▼> keys to set a new value
- Press <ENTER> + <STEP> keys to load memory the new value.
- Press <SELECT> key to obtain the indication below:

Ramp : Up

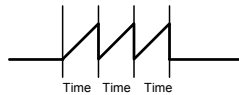

Ramp : Up Down

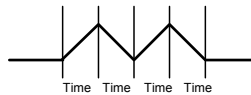

Ramp : Up Soak Down

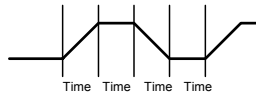

- Press <▲> and <▼> keys to set different ramp.
 - Press <ENTER> + <SELECT> keys to load memory with the new value.
 - To simplify the setting procedure, press simultaneously <▲> and <▼> keys to zero the indicated value.
 - To exit the set-up procedure press <0.1> or <1> key. The instrument will return to the operative mode previously in use.
 - To start the ramp program set the instrument in simulation mode (-OUT-) and press the <AUTORAMP> key.
- On the display will appear the following indication:

Prg +210.0°C F

- To exit the simulation program press one of the two <0.1°> or <1°> keys.

Autoramp Application Note

During the set-up procedure the operator must consider the limitation on steep ramps due to the minimum time required by the step generation (30ms).
For a correct set-up take into consideration the following equation:



$$\frac{\text{Time} \times \text{Step}}{\text{End} - \text{Start}} > 0,03$$

If the above requirement is not fulfilled the operator can still estimate the actual time using the following equation:

$$\text{Time} \approx \frac{\text{End} - \text{Start}}{\text{Step}} \times 0,03$$

Example

In the case of the following set-up:

Start = 0
 End = 1000°C
 Step = 1°C
 Time = 10 sec.

$$\frac{10 \times 1}{(1000 - 0) + 1} = \frac{10}{1001} = 0,01$$

The result of the equation does not meet the correct requirements as 0,01 is lower than 0,03. Therefore the total time of ramp will be:

$$\text{Time} = \frac{(1000-0)+1}{1} \times 0,03 = 30 \text{ sec.}$$

To obtain a total time of 10 sec., the operator should set the step value at 3°C.

8.5.9 ITS90 - IPTS68 Temperature Scale selection

- To change the linearization curve from IPTS68 to ITS90 (or viceversa), press <SHIFT> + <FAST> keys:

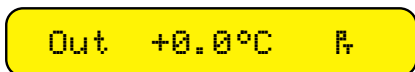

8.5.10 Scale Factor Mode

The "scale factor" mode is an easy menu-driven set-up to read or to simulate custom Rtd with Ro and a adjustable (linear interpolation).

You can set Ro from 8.00Ω to 210.00Ω or from 80.0Ω to 2100.0Ω

You can set a from 1.000 x 10⁻³ to 10.000 x 10⁻³.

The example explains the procedure of installing the "scale factor" function for the calibration of a potentiometric recorder with a special Rtd input with:

$$\begin{aligned} R_0 &= 110\Omega \text{ and} \\ \alpha &= 3.85 \times 10^{-3}. \end{aligned}$$

- Press <SELECT> key, use <▲> and <▼> keys to select "X scaling" mode and press again <SELECT> key to enter the set-up procedure. The display will indicate as follows:

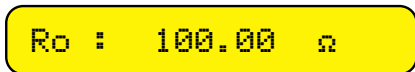



- Press **<0.1>** or **<1>** key to shift the decimal point position (400Ω / 4000Ω range).
- Press **<▲>** and **<▼>** key to adjust the required value.
- Press the **<ENTER>** key to load in the memory the new value.
The display will indicate as shown below:



→ : 3.850 × 10⁻³

- Press keys **<▲>** and **<▼>** to adjust the full scale value
- Press the **<ENTER>** key to load in the memory the symbol.
The display will indicate the scaled In/ Out value.

8.5.11 Installation parameter mode

- To start this procedure press the **<ENTER>** key before switching the instrument -ON- .
- The display will indicate as follows:



PCAL +1 N=0

(the numerical value indicated is only an example)

8.5.11.1 Firmware release code

From the above step of the procedure it is possible to display the memory program release code.

- Press **<IN/OUT>** key.
The reading on the display indicates that the instrument is equipped with a memory version 1.000:



Version 1.000

The above information is extremely useful to understand the update status of the instrument and to simplify information exchange with EUROTRON engineers during repair or service operations.

- Press any key to exit the procedure.
The display will indicate again as it follows:



→ : 3.850 × 10⁻³

- Switch the instrument -OFF- to end this step of the program procedure.

8.6 Faulty operating conditions

During start up, measuring or simulation modes, faulty condition of the instrument will be announced with coded messages as follows:



Error Checksum 1



- indicates a possible loss of data on "AUTORAMP" program or on the three manual memories ("0", "1", "2")

Error Checksum 2

- indicates a possible loss of data on "PROGRAM X"

Error Checksum 3

- indicates a possible loss of data on "AUTORAMP", "PROGRAM X" and / or on the three manual memories ("0", "1", "2") - (error 1 + error 2)

Error Checksum 4

- indicates a possible loss of calibration data

Error Checksum 5

- indicates a possible loss of calibration data, and / or "AUTORAMP" data and/or on the three manual memories (error 1 + error 4)

Error Checksum 6

- indicates a possible loss of calibration data and/or "PROGRAM X" data (error 2 + error 4)

Error Checksum 7

- indicates a possible loss of calibration data, and /or "AUTORAMP" data, "PROGRAM X" and on the three manual memories error 3 + error 4)

!!! ERROR 9 !!!

- indicates a data writing on the EEPROM memory not verified

- UNDER -

- indicates "underflow" conditions

+ OVER +

- indicates "overflow" conditions

Error 7



- indicates a possible error during “Scale Factor” computation

Error 0

- indicates that the D/A converter has reached it's minimum/maximum value.

The above indicated faulty conditions can be announced both during the autodiagnostic routine or in measuring or simulation modes.

If the faulty condition is critical for the type of application it is recommended to re-run the pertinent set-up procedure.

8.7 Digital interface

The **UniCal Rtd +** portable calibrator is equipped with a digital interface.

The interface circuit is essentially based on the serial communication interface subsystem (SCI) on the chip of the microprocessor.

The output voltage levels are TTL at 0 to +5 V.

An optional adaptor to convert the voltage level from 0 to +5 V to RS232 levels can be supplied on request,

This adaptor is required to interface the **UniCal Rtd +** with a Personal Computer.

- To enter the procedure, press the **<ON>** + **<ENTER>** keys; the display will be as follows:

CAL 10056 N=0

- To enter the program mode press the **<2>** key;
The numerical value of the “baud rate” can be one of the following:
19200 - 9600 - 4800 - 2400 - 1200 - 600 - 300
- Select, through the **<▲>** or **<▼>** keys the “baud rate” used by the receiver unit and transmission lines.
- Press the **<2>** key to load the value in the memory; the display will indicate as it follows:

ID Name: 99

The above number represents the address code assigned to the instrument

It can be programmed from 00 to 99 through the **<▲>** or **<▼>** keys.

Load the set value in the memory by pressing the **<2>** key

- The display will return to the original indication:

CAL 10056 N=0

- To exit the procedure press the **<OFF>** key.

8.7.2 Digital output wiring practice

The wiring to the digital output signals is made through a mini connector mounted on the right side of the case.

The pertinent connections are indicated below:

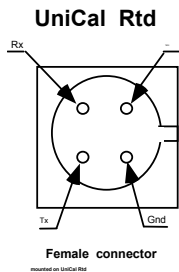

8.7.3 TTL to RS232 Adaptor

The adaptor consists of a cable to which is connected a male mini DIN connector (to the **UniCal Rtd +** and a DB 25 connector, that contains the electrical circuitry, to the Personal Computer.

The basic circuit and interconnections are indicated below:

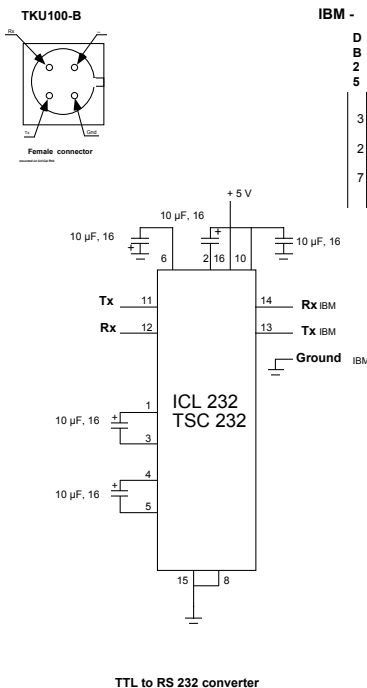

8.7.4 Communication Protocol from UniCal Rtd to a PC

The exchange of information when a **UniCal Rtd +** is interconnected with a Personal Computer (MS-DOS IBM or 100% compatible) are as follows:

Computer request

Computer

Tx IDNAME →
 Rx IDNAME ←
 Tx Instruction →
 Rx Instruction ←

UniCal Rtd +

Rx IDNAME
 Tx IDNAME
 Rx Instruction
 Tx Instruction

Proceed if name acknowledged
rif not, do not answer



Tx char	→	Rx char
Rx DATA 1	←	Tx DATA 1
Tx char	→	Rx char
Rx DATA 2	←	Tx DATA 2
Tx char	→	Rx char
Rx DATA 3	←	Tx DATA 3
Tx char	→	Rx char
Rx DATA 4	←	Tx DATA 4
Tx char	→	Rx char
Rx CHKSUM	←	Tx CHKSUM

IDNAME, Instruction, DATA 1, DATA 2, DATA 3, DATA 4 e CHKSUM are 8 bit decimal values (1byte)

Notes	Instruct	DATA 1	DATA 2	DATA 3	DATA 4
Actual value	24	display(actual)	lin(actual)	Value Hi(actual)	Value Lo(actual)
STO 0 Group A	164	x	x	Display (0)	Lin (0)
STO 0 Group A	165	Value Hi (0)	Value Lo (0)	x	x
STO 1 Group A	165	x		x	Display (1) Lin (1)
STO 1 Group A	166	Value Hi (1)	Value Lo (1)	x	x
STO 2 Group A	166	x		x	Display (2) Lin (2)
STO 2 Group A	167	Value Hi (2)	Value Lo (2)	x	x
STO 0 Group B	168	x		x	Display (0) Lin (0)
STO 0 Group B	169	Value Hi (0)	Value Lo (0)	x	x
STO 1 Group B	169	x		x	Display (1) Lin (1)
STO 1 Group B	170	Value Hi (1)	Value Lo (1)	x	x
STO 2 Group B	170	x		x	Display (2) Lin (2)
STO 2 Group B	171	Value Hi (2)	Value Lo (2)	x	x
STO 0 Group C	172	x		x	Display (0) Lin (0)
STO 0 Group C	173	Value Hi (0)	Value Lo (0)	x	x
STO 1 Group C	173	x		x	Display(1) Lin (1)
STO 1 Group C	174	Value Hi (1)	Value Lo (1)	x	x
STO 2 Group C	174	x		x	Display (2) Lin (2)
STO 2 Group C	175	Value Hi (2)	Value Lo (2)	x	x
STO 0 Group D	176	x		x	Display (0) Lin (0)
STO 0 Group D	177	Value Hi (0)	Value Lo (0)	x	x
STO 1 Group D	177	x		x	Display (1) Lin (1)
STO 1 Group D	178	Value Hi (1)	Value Lo (1)	x	x
STO 2 Group D	178	x		x	Display (2) Lin (2)
STO 2 Group D	179	Value Hi (2)	Value Lo (2)	x	x
STO 0 Group E	180	x		x	Display (0) Lin (0)
STO 0 Group E	181	Value Hi (0)	Value Lo (0)	x	x
STO 1 Group E	181	x		x	Display (1) Lin (1)
STO 1 Group E	182	Value Hi (1)	Value Lo (1)	x	x
STO 2 Group E	182	x		x	Display (2) Lin (2)
STO 2 Group E	183	Value Hi (2)	Value Lo (2)	x	x
STO 0 Group F	184	x		x	Display (0) Lin (0)
STO 0 Group F	185	Value Hi (0)	Value Lo (0)	x	x
STO 1 Group F	185	x		x	Display (1) Lin (1)
STO 1 Group F	186	Value Hi (1)	Value Lo (1)	x	x
STO 2 Group F	186	x		x	Display (2) Lin (2)
STO 2 Group F	187	Value Hi (2)	Value Lo (2)	x	x
STO 0 Group G	188	x	x	Display (0)	Lin (0)
STO 0 Group G	189	Value Hi (0)	Value Lo (0)	x	x
STO 1 Group G	189	x		x	Display (1) Lin (1)
STO 1 Group G	190	Value Hi (1)	Value Lo (1)	x	x
STO 2 Group G	190	x		x	Display (2) Lin (2)
STO 2 Group G	191	Value Hi (2)	Value Lo (2)	x	x
STO 0 Group H	192	x		x	Display (0) Lin (0)
STO 0 Group H	193	Value Hi (0)	Value Lo (0)	x	x
STO 1 Group H	193	x		x	Display (1) Lin (1)
STO 1 Group H	194	Value Hi (1)	Value Lo (1)	x	x
STO 2 Group H	194	x		x	Display (2) Lin (2)



STO 2 Group H	195	Value Hi (2)	Value Lo (2)	x	x
RAMP	132	x	x	Time Hi	Time Lo
RAMP	133	Start Hi	Start Lo	Stop Hi	Stop Lo
RAMP	134	Step Hi	Step Lo	Lin	Display
RAMP	135	Mode	x	x	x
X SCALING	136	Value Hi (Ro)	Value Lo (Ro)	alpha Hi (Ro)	alpha Hi (Ro)
X SCALING	137	Decimal point	x	x	x
VARIE	141	x	STO group	x	x
VARIE	32	Vbat	x	x	x

- display (name).AND.8 =
- 0 = ITS68
 - 8 = ITS90
- display (name).AND.07hex =
- 0 = 1.9999
 - 1 = 19.999
 - 2 = 199.99
 - 3 = 1999.9
 - 4 = 19999
- display (name).AND.40hex =
- 0 = °C
 - 40hex = °F
- display (name).AND.20hex =
- 0 = IN
 - 20hex = OUT
- lin (name)
- 0 = Pt 100 IEC
 - 1 = Pt 100 US
 - 2 = Pt 100 US LAB
 - 3 = Pt 100 SAMA
 - 4 = Pt 100 OIML
 - 5 = Pt 100 JIS
 - 6 = NI 100
 - 7 = NI 120
 - 8 = CU 10
 - 9 = CU 100
 - 10 = Pt 200
 - 11 = Pt 500
 - 12 = Pt 1000 IEC
 - 13 = Pt 1000 OIML
 - 14 = X scaling
- Lin (name).AND.80hex =
- 0 = value OK
 - 80hex = error
- if line (name).AND.80hex = 80hex corresponding "Value Lo"
- 0 = under
 - 1 = over
 - 2 = error 7
 - 3 = error 2
 - 4 = error 6
 - 6 = error 0
- if line (name).AND.80hex = 0
value (name) = 2nd complement (16 bit) Value Hi (name).256 + Value Lo (name)
- Mode =
- 0 = Up
 - 1 = Up Down
 - 2 = Up Soak Down
- STO Group selected
- 0 = A
 - 1 = B
 - 2 = C
 - ... = ...
 - n (max. 7) = n (max. H)
- Volt Vbat = (Vbat x 2) / 51

CHKSUM (checksum) - (DATA1 + DATA2 + DATA3 + DATA4). AND. FF
 The above is useful to verify a correct transmission and receival.
 The minimum time-out of the **UniCal Rtd +** is 5 seconds.

8.7.5 Computer request for UniCal settings



The computer must split a 16 bit word into 2 words of 8 bit as follows:

Computer		UniCal Rtd +	
Tx IDNAME	→	Rx IDNAME	Proceed if the name is acknowledged, if not he will
Rx IDNAME	←	Tx IDNAME	not answer
Tx Instruction	→	Rx Instruction	
Rx Instruction	←	Tx Instruction	
Tx DATA 1	→	Rx DATA 1	
Rx char	←	Tx char	
Tx DATA 2	→	Rx DATA 2	
Rx char	←	Tx char	
Tx DATA 3	→	Rx DATA 3	
Rx char	←	Tx char	
Tx DATA 4	→	Rx DATA 4	
Rx char	←	Tx char	
Tx CHKSUM	→	Rx CHKSUM	
Rx char	←	Tx char	

Notes	Instr	DATA 1	DATA 2	DATA 3	DATA 4	A	B
Set Lin	25	Lin (actual)	x	x	x	-----	
Set display	26	Display (actual)	x	x	x	-----	
Set value	27	Value Hi (Out)	Value Lo (Out)	x	x	-----	
Start ramp	28	x	x	x	x	-----	
Start ramp	33	x	x	x	x	-----	
TIME RAMP	127	0	18	Time Hi	Time Lo	0	16
START RAMP	127	0	20	Start Hi	Start Lo	0	16
STOP RAMP	127	0	22	Stop Hi	Stop Lo	0	16
STEP RAMP	127	0	24	Step Hi	Step Lo	0	16
Lin/Dis RAMP	127	0	26	Lin	Display	0	16
MODE RAMP	127	0	28	Mode	0	0	16
Dis/Lin STO 0 #A	127	0	146	Display (0)	Lin (0)	0	144
Value STO 0 #A	127	0	148	Value Hi (0)	Value Lo (0)	0	144
Dis/Lin STO1 #A	127	0	150	Display (1)	Lin (1)	0	144
Value STO 1 #A	127	0	152	Value Hi (1)	Value Lo (1)	0	144
Dis/Lin STO 2 #A	127	0	154	Display (2)	Lin (2)	0	144
Value STO 2 #A	127	0	156	Value Hi (2)	Value Lo (2)	0	144
Dis/Lin STO 0 #B	127	0	162	Display (0)	Lin (0)	0	160
Value STO 0 #B	127	0	164	Value Hi (0)	Value Lo (0)	0	160
Dis/Lin STO1 #B	127	0	166	Display (1)	Lin (1)	0	160
Value STO 1 #B	127	0	168	Value Hi (1)	Value Lo (1)	0	160
Dis/Lin STO 2 #B	127	0	170	Display (2)	Lin (2)	0	160
Value STO 2 #B	127	0	172	Value Hi (2)	Value Lo (2)	0	160
Dis/Lin STO 0 #C	127	0	178	Display (0)	Lin (0)	0	176
Value STO 0 #C	127	0	180	Value Hi (0)	Value Lo (0)	0	176
Dis/Lin STO 1 #C	127	0	182	Display (1)	Lin (1)	0	176
Value STO 1 #C	127	0	184	Value Hi (1)	Value Lo (1)	0	176
Dis/Lin STO 2 #C	127	0	186	Display (2)	Lin (2)	0	176
Value STO 2 #C	127	0	188	Value Hi (2)	Value Lo (2)	0	176
Dis/Lin STO 0 #D	127	0	194	Display (0)	Lin (0)	0	192
Value STO 0 #D	127	0	196	Value Hi (0)	Value Lo (0)	0	192
Dis/Lin STO 1 #D	127	0	198	Display (1)	Lin (1)	0	192
Value STO 1 #D	127	0	200	Value Hi (1)	Value Lo (1)	0	192
Dis/Lin STO 2 #D	127	0	202	Display (2)	Lin (2)	0	192
Value STO 2 #D	127	0	204	Value Hi (2)	Value Lo (2)	0	192
Dis/Lin STO 0 #E	127	0	210	Display (0)	Lin (0)	0	208
Value STO 0 #E	127	0	212	Value Hi (0)	Value Lo (0)	0	208
Dis/Lin STO 1 #E	127	0	214	Display (1)	Lin (1)	0	208
Value STO 1 #E	127	0	216	Value Hi (1)	Value Lo (1)	0	208



Dis/Lin STO 2 #E	127	0	218	Display (2)	Lin (2)	0	208
Value STO 2 #E	127	0	220	Value Hi (2)	Value Lo (2)	0	208
Dis/Lin STO 0 #F	127	0	226	Display (0)	Lin (0)	0	224
Value STO 0 #F	127	0	228	Value Hi (0)	Value Lo (0)	0	224
Dis/Lin STO 1 #F	127	0	230	Display (1)	Lin (1)	0	224
Value STO 1 #F	127	0	232	Value Hi (1)	Value Lo (1)	0	224
Dis/Lin STO 2 #F	127	0	234	Display (2)	Lin (2)	0	224
Value STO 2 #F	127	0	236	Value Hi (2)	Value Lo (2)	0	224
Dis/Lin STO 0 #G	127	0	242	Display (0)	Lin (0)	0	240
Value STO 0 #G	127	0	244	Value Hi (0)	Value Lo (0)	0	240
Dis/Lin STO 1 #G	127	0	246	Display (1)	Lin (1)	0	240
Value STO 1 #G	127	0	248	Value Hi (1)	Value Lo (1)	0	240
Dis/Lin STO 2 #G	127	0	250	Display (2)	Lin (2)	0	240
Value STO 2 #G	127	0	252	Value Hi (2)	Value Lo (2)	0	240
Dis/Lin STO 0 #H	127	1	2	Display (0)	Lin (0)	1	0
Value STO 0 #H	127	1	4	Value Hi (0)	Value Lo (0)	1	0
Dis/Lin STO 1 #H	127	1	6	Display (1)	Lin (1)	1	0
Value STO 1 #H	127	1	8	Value Hi (1)	Value Lo (1)	1	0
Dis/Lin STO 2 #H	127	1	10	Display (2)	Lin (2)	1	0
Value STO 2 #H	127	1	12	Value Hi (2)	Value Lo (2)	1	0

Notes	Instr	DATA 1	DATA 2	DATA 3	DATA 4	A	B
CHKSUM recal.	47	A	B	0	0	-----	
SELECT GROUP	75	Group	0	0	0	-----	

Remember that the computer must split one 16 bit word into two 8 bit words as it follows

Value Hi (....) Value Lo (....)
 Higher 8 bit Lower 8 bit
 CHKSUM = (DATA1 + DATA2 + DATA3 + DATA4).AND.7F

8.7.6 Communication Programs

In this chapter are illustrated two examples of communication programs between the **UniCal Rtd +** and an IBM or IBM compatible Personal Computer.

Example A:

Data transfer from UniCal Rtd + to PC (see section 8.7.4)

Set IDNAME=1 and BAUD RATE=9600 on **UniCal Rtd +** see 8.7.1).

Connect **UniCal Rtd +**, through adapter BB530001 (TTL - RS232 converter), to personal computer communication port COM1.

Set the **UniCal Rtd +** in Pt100 measurement (IN) mode. Run the program and you will see on the screen of the computer the actual measured value (once).

Example B:

PC instructions to UniCal Rtd + (see section 8.7.5):

Set IDNAME=1 and BAUD RATE=9600 on the **UniCal Rtd +** (see 8.7.1).

Connect **UniCal Rtd +**, through adapter BB530001 (TTL - RS232 converter), to personal computer communication port COM1.

Set the **UniCal Rtd +** in OUT mode; running the program the **UniCal Rtd +** will be automatically set to 200.0 °C.

Example A:

```
1Ø CHAR = Ø
2Ø IDNAME = 1
3Ø INSTRUCTION = 24
35 OPEN "COM1: 96ØØ, N,8,1,CD,CS,DS,RS" FOR RANDOM AS # 1
```



```
40 PRINT #1, CHR$ (IDNAME)::REM TRANSMIT IDNAME TO UniCal Rtd +
50 WHILE LOC (1) = 0: WEND: REM WAIT RECEIVING IDNAME FROM UniCal Rtd +
60 IDNAME = ASC (INPUT$ (1, 1)): REM READ RECEIVED IDNAME FROM UniCal Rtd +
70 PRINT #1, CHR$ (INSTRUCTION);
80 WHILE LOC (1) = 0: WEND
90 INSTRUCTION = ASC (INPUT$ (1, 1))
100 PRINT #1, CHR$ (CHAR);
110 WHILE LOC (1) = 0: WEND
120 DATA 1 = ASC (INPUT$ (1, 1))
130 PRINT #1, CHR$ (CHAR);
140 WHILE LOC (1) = 0: WEND
150 DATA 2 = ASC (INPUT$ (1, 1))
160 PRINT #1, CHR$ (CHAR);
170 WHILE LOC (1) = 0: WEND
180 DATA 3 = ASC (INPUT$ (1, 1))
190 PRINT #1, CHR$ (CHAR);
200 WHILE LOC (1) = 0: WEND
210 DATA 4 = ASC (INPUT$ (1, 1))
220 PRINT #1, CHR$ (CHAR);
2310 WHILE LOC (1) = 0: WEND
240 CHKSUM = ASC (INPUT$ (1, 1))
250 IF CHKSUM <> ((DATA1 + DATA2 + DATA3 + DATA4) AND &HFF) THEN PRINT "Error": END
260 VALUE = DATA3 * 256 + DATA4
270 IF VALUE > 32767 THEN VALUE =VALUE - 65536: REM 2'S COMPLEMENT
280 PRINT "VALUE: " ; VALUE / 10
290 END
```

Example B:

```
10 CHAR = 0
20 IDNAME = 1
30 INSTRUCTION = 27
40 VALUE = 200
50 VALUE$ = HEX$ (VALUE)
55 WHILE LEN (VALUE$)<4: VALUE$ ="0"+VALUE$: WEND
60 IF LEN (VALUE$) > 4 THEN VALUE$ =RIGHT$ (VALUE$,4)
65 DATA1 = VAL ("&H" + LEFT$ (VALUE$, 2))
70 DATA2 = VAL ("&H" +RIGHT$ (VALUE$, 2))
75 DATA3 = 0
80 DATA4 = 0
90 CHKSUM = (DATA1 + DATA2 + DATA3 + DATA4) AND &H7F
130 OPEN "COM1: 9600,N,8,1,CD,CS,DS,RS" FOR RANDOM AS #1
140 PRINT #1, CHR$ (IDNAME) ; : REM TRANSMIT IDNAME TO UniCal Rtd +
150 WHILE LOC (1) = 0: WEND: REM WAIT RECEIVING IDNAME FROM UniCal Rtd +
160 IDNAME = ASC (INPUT$ (1, 1)): REM READ RECEIVED IDNAME FROM UniCal Rtd +
170 PRINT #1, CHR$ (INSTRUCTION) ;
180 WHILE LOC (1) = 0: WEND
190 INSTRUCTION = ASC (INPUT$ (1, 1))
200 PRINT #1, CHR$ (DATA1) ;
210 WHILE LOC (1) = 0: WEND
220 CHAR = ASC (INPUT$ (1, 1))
230 PRINT #1, CHR$ (DATA2) ;
240 WHILE LOC (1) = 0: WEND
250 CHAR = ASC (INPUT$ (1, 1))
260 PRINT #1, CHR$ (DATA3) ;
270 WHILE LOC (1) = 0: WEND
280 CHAR = ASC (INPUT$ (1, 1))
290 PRINT #1, CHR$ (DATA4) ;
300 WHILE LOC (1) = 0: WEND
310 CHAR = ASC (INPUT$ (1, 1))
```



```
32Ø PRINT #1, CHR$ (CHKSUM) ;  
33Ø WHILE LOC (1) = Ø : WEND  
34Ø CHAR = ASC (INPUT$ (1 , 1))  
35Ø PRINT "Transmitted."  
39Ø END
```



9 MAINTENANCE

The **UniCal Rtd +** portable calibrator has been factory tested and calibrated before shipment. The calibration should be verified and re-adjusted if the instrument is showing an error exceeding the declared specifications or when a critical active or passive component is replaced (either at component level or at board level)

The **UniCal Rtd +** portable calibrator uses sophisticated analog and digital technologies.

Service requires highly trained personnel.

EUROTRON will supply, on request, a technical reference manual, with all instructions and recommendation for service and calibration.

EUROTRON engineers will give prompt support for any requests of assistance.

9.1 Safety recommendations

Primary elements (i.e. thermocouples, resistance thermometers, etc.) are normally linked to electrical potentials equal or near to the ground potential. However, in some applications, there may be present a common mode voltage to earth.

Check for the voltage between input terminals and ground as this voltage can be transmitted to other devices connected to the calibrator.

9.2 Spare parts

EE620004	Alkaline battery (n. 1 piece - n. 4 required)
EE620008	Ni-Cd rechargeable battery (n. 1 piece - n. 4 required)
BB880001	Vynil case
EE700115	Male connector for digital port
BB530003	Normal TTL to RS232 adaptor
EE670006	100 mA fuse
BB290001	110 V 50/60 Hz battery charger with US plug
BB290000	230 V 50/60 Hz battery charger with Schuko plug
BB290004	240 V 50/60 Hz battery charger with UK plug
BB290013	230 V 50/60 Hz battery charger with European plug
BB260004	Demo software package
EE210112	Display label

9.3 Storage

If the instrument is left unused for a long time, it is recommended to remove batteries.

Store the instrument in the original package at a temperature from -30°C to +60°C, with R.H. less than 90% (non condensing).

If the instrument has been unused for a month check the battery voltage and charge the Ni-Cd batteries for at least 12 hours.



10 CERTIFICATES

10.1 Certificate of warranty

Each instrument is shipped with a Warranty Certificate that indicates the validity conditions of the warranty itself. **Eurotron** warrants its products against defects in materials and workmanship.

If the unit should malfunction, it must be returned during the warranty period, transportation prepaid, to **Eurotron** for evaluation. Upon examination, if the unit is found to be defective it will be repaired or replaced at no charge.

Eurotron's WARRANTY does not apply to defects resulting from any action of the purchaser, including but not limited to mishandling, improper interfacing, operation outside of design limits, improper repair, or unauthorised modification. This WARRANTY is VOID if the unit shows evidence of having been tampered with or shows evidence of being damaged as a result of excessive corrosion; or current, heat, moisture or vibration; improper specification; misapplication; misuse or other operating conditions outside of **Eurotron's** control.

This warranty applies to the original purchaser only. Please include a copy of the original invoice or a small service charge may be applied.

Direct all warranty and repair requests/inquiries to the **Eurotron** Customer Service Department. BEFORE RETURNING ANY PRODUCT(S) TO **EUROTRON**, PURCHASER MUST OBTAIN AN AUTHORIZED RETURN (AR) NUMBER FROM **EUROTRON'S** CUSTOMER SERVICE DEPARTMENT (IN ORDER TO AVOID PROCESSING DELAYS).

The purchaser is responsible for shipping charges, freight, insurance and proper packaging to prevent breakage in transit.

10.2 Certificate of conformity

Each instrument is shipped with a Letter of Conformity, to grant that the characteristics of the instrument correspond to the required ones, and that the instrument calibration is traceable to National and International Standards.

The instrument has been found to conform in all respects to specifications, drawings, workmanship standards and order requirements.



APPENDIX



Declaration of Conformity

We : EUROTRON Instruments S.p.A.

(Supplier's name)

Via F.lli Casiraghi 409/413 - 20099 Sesto S. Giovanni (MI) - Italy

(Address)

declare under our sole responsibility that the product :

Resistance Thermometer Indicator - Simulator type UniCal Rtd+

(Name and type)

cat. 3112

(Model)

to which this declaration relates is in conformity with the following normative documents :

EN 50082-2 (3/95)

IEC 1000-4-2 / IEC 1000-4-4 / IEC 1000-4-11

ENV 50140 - ENV 50141 - ENV 50204

EN 55011

(Title, number and date of issue of normative documents)

following the prevision of directive :

89/336/CEE Electromagnetic Compability (EMC)

Sesto S. Giovanni, January 08th, 1996

(Place and date of issue)

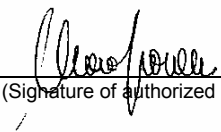
(Signature of authorized person)

